



ALPHA INDUSTRIAL SERVICES

Transport & Cold Chain Solutions

Built for Performance.
Engineered to Last.

alphaiksa.com





About Alpha

We build high-performance transport and cold chain solutions.

From truck body systems to cold storage, we deliver reliable, efficient, and scalable solutions for modern logistics.

Trusted by industry leaders. Built for real-world performance.





Our Services

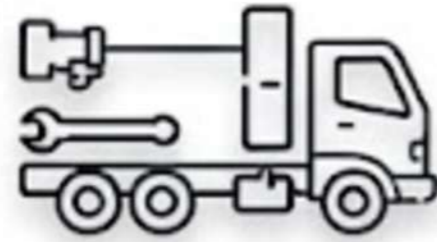

**Truck Body
Accessories**



**Cold Storage
Rooms**

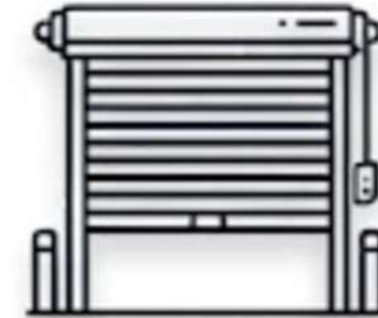

**Roller Shutter Doors
& Curtain Systems**



**Tail Lift & Insulated
Vehicles**

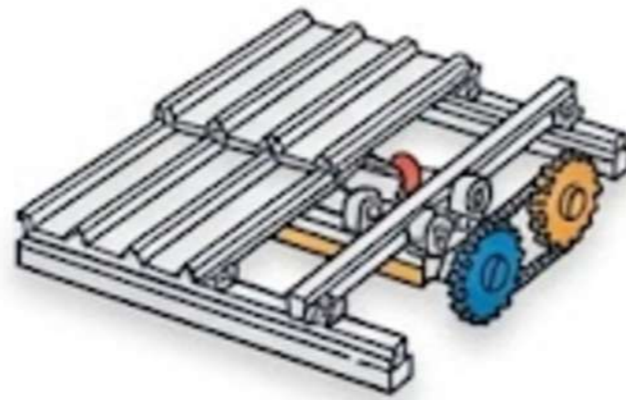

**Sliding Roof
Systems**

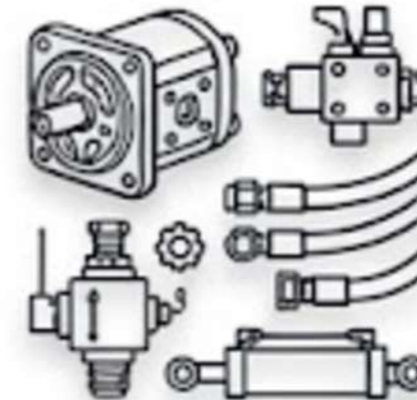

**Hydraulic Systems
& Accessories**



+++

TRUCK CURTAIN SLIDING SYSTEMS

- **Faster access.
Smarter loading.**
- Quick side loading
- Flexible access
- Strong aluminum system
- Custom branding options



   alphaiksa.com





Buckle Sliding System

Built for strength.
Designed for control.

Key Features

- Secure cargo protection
- Heavy-duty structure
- Smooth operation
- Reliable performance

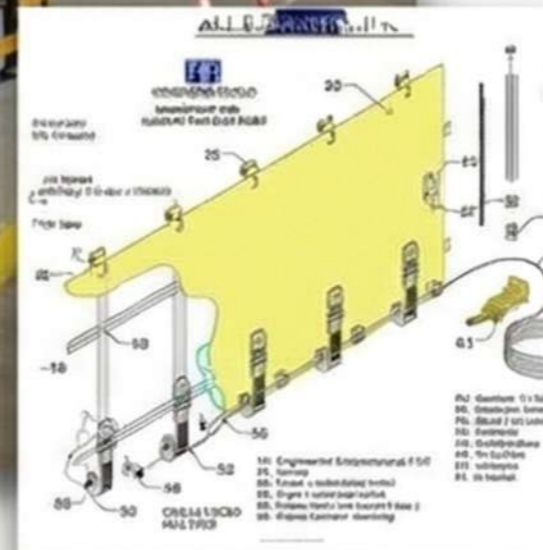



OUR WORK

Real projects. Real results.

alphaiksa.com



Cold Storage

Precision cooling. Maximum reliability.
-40°C to +10°C

Applications

- Food & Beverage
- Pharmaceuticals
- Agriculture

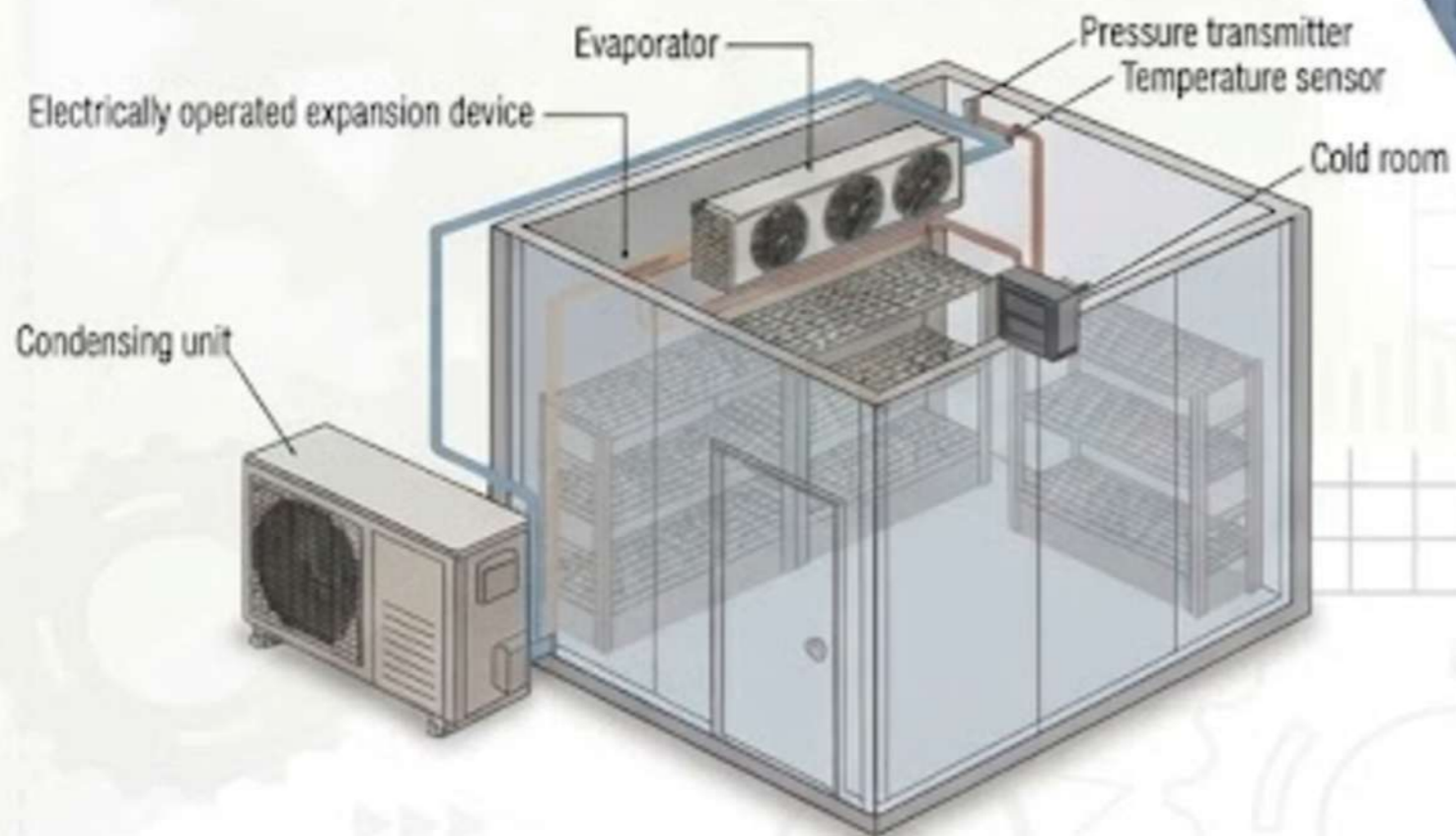



Roller Shutter Systems

Fast access. Zero wasted space.

Applications

- Delivery vehicles
- Service trucks
- Emergency units





Tail Lift & Insulated Vehicles

Load faster. Deliver smarter.
Built for **demanding logistics.**





Industrial Equipment & Accessories

Precision tools for serious production.



Laser Welding Machines



Cutting & Bending Machines



Polishing Machines



Freezing Equipment



Eccentric Press Machines





Sliding Roof Systems

Open up. Close down. Stay in control.

Retractable panels that adapt to your space—open for sun, adjust for shade, or fully close for protection.

Key Benefits

- Fully retractable
- Adjustable light control
- Weather-resistant
- Smooth operation

Applications

- Cafés & Restaurants
- Outdoor seating
- Terraces & patios
- Commercial spaces





Trusted By
Chosen by leading brands.





Let's Work Together



+961 03 718 807



+966 50 149 7345



Rabih@alphaiksa.com



alphaiksa.com